



Leading education
and social research
Institute of Education
University of London

UPMAP 2010 Mathematics and Physics Year 12

Dear Student,

Please read this section before you begin

In this questionnaire, we want to find out more about the reasons some students continue to study mathematics or physics after the age of 16 and others do not.

We hope you will answer all the questions but if you feel uncomfortable with a particular question feel free to skip it.

All answers are confidential.

Your teachers and your school will not see your answers.

Thank you



1. ABOUT YOU

a) What is your first name? (Please write in capital letters, one letter per box)

--	--	--	--	--	--	--	--	--	--	--	--	--	--	--	--	--	--	--	--	--

b) What is your surname? (Please write in capital letters, one letter per box)

--	--	--	--	--	--	--	--	--	--	--	--	--	--	--	--	--	--	--	--	--

c) What is your gender?

Male

Female

d) What is your date of birth?

Day

--	--

Month

--	--

Year

--	--	--	--

e) What is the name of your school? (Please write in capital letters, one letter per box)

--	--	--	--	--	--	--	--	--	--	--	--	--	--	--	--	--	--	--	--	--

f) For your GCSEs or equivalent qualifications:

i) in which year did you start your maths course?

Year 9	Year 10	Year 11	Year 12 retake
<input type="checkbox"/>	<input type="checkbox"/>	<input type="checkbox"/>	

ii) in which year did you finish your maths course?

<input type="checkbox"/>	<input type="checkbox"/>	<input type="checkbox"/>	<input type="checkbox"/>
--------------------------	--------------------------	--------------------------	--------------------------

iii) in which year did you start your science course?

<input type="checkbox"/>	<input type="checkbox"/>	<input type="checkbox"/>	
--------------------------	--------------------------	--------------------------	--

iv) in which year did you finish your science course?

<input type="checkbox"/>	<input type="checkbox"/>	<input type="checkbox"/>	<input type="checkbox"/>
--------------------------	--------------------------	--------------------------	--------------------------

g) How many science GCSEs or equivalent qualifications did you take?

One

Two

Three

h) What grades did you get for your GCSEs or equivalent qualifications?

Maths:

Science:

2. YOUR CURRENT STUDIES

What subjects have you selected for post-16 study (e.g. A-Levels, IB, BTECH, etc.), and why did you select these? (Please write down e.g. your four A- or AS-level choices, your six IB choices, or any equivalent number of options.)

Please write them down in order of your preference, and tick a reason why you selected the subject:

	Because I need it for higher education entry	Because I need it for my career	Because I was advised to take it by teachers/careers advisors	Because I was advised to take it by my family or friends	Because I am good at it	For another reason
1.	<input type="checkbox"/>	<input type="checkbox"/>	<input type="checkbox"/>	<input type="checkbox"/>	<input type="checkbox"/>	<input type="checkbox"/>
2.	<input type="checkbox"/>	<input type="checkbox"/>	<input type="checkbox"/>	<input type="checkbox"/>	<input type="checkbox"/>	<input type="checkbox"/>
3.	<input type="checkbox"/>	<input type="checkbox"/>	<input type="checkbox"/>	<input type="checkbox"/>	<input type="checkbox"/>	<input type="checkbox"/>
4.	<input type="checkbox"/>	<input type="checkbox"/>	<input type="checkbox"/>	<input type="checkbox"/>	<input type="checkbox"/>	<input type="checkbox"/>
5.	<input type="checkbox"/>	<input type="checkbox"/>	<input type="checkbox"/>	<input type="checkbox"/>	<input type="checkbox"/>	<input type="checkbox"/>
6.	<input type="checkbox"/>	<input type="checkbox"/>	<input type="checkbox"/>	<input type="checkbox"/>	<input type="checkbox"/>	<input type="checkbox"/>
7.	<input type="checkbox"/>	<input type="checkbox"/>	<input type="checkbox"/>	<input type="checkbox"/>	<input type="checkbox"/>	<input type="checkbox"/>
8.	<input type="checkbox"/>	<input type="checkbox"/>	<input type="checkbox"/>	<input type="checkbox"/>	<input type="checkbox"/>	<input type="checkbox"/>
9.	<input type="checkbox"/>	<input type="checkbox"/>	<input type="checkbox"/>	<input type="checkbox"/>	<input type="checkbox"/>	<input type="checkbox"/>
10.	<input type="checkbox"/>	<input type="checkbox"/>	<input type="checkbox"/>	<input type="checkbox"/>	<input type="checkbox"/>	<input type="checkbox"/>

3. MORE ABOUT YOU

For each of the questions please tick **one** choice that best represents your response to each statement or question.

	Not at all	Less than once a month	Once or twice a month	Once a week	More than once a week
How often do you take part in the following activities:					
a) Maths clubs?	<input type="checkbox"/>	<input type="checkbox"/>	<input type="checkbox"/>	<input type="checkbox"/>	<input type="checkbox"/>
Physics clubs?	<input type="checkbox"/>	<input type="checkbox"/>	<input type="checkbox"/>	<input type="checkbox"/>	<input type="checkbox"/>
b) Maths Master classes?	<input type="checkbox"/>	<input type="checkbox"/>	<input type="checkbox"/>	<input type="checkbox"/>	<input type="checkbox"/>
Physics Master classes?	<input type="checkbox"/>	<input type="checkbox"/>	<input type="checkbox"/>	<input type="checkbox"/>	<input type="checkbox"/>
c) Maths competitions?	<input type="checkbox"/>	<input type="checkbox"/>	<input type="checkbox"/>	<input type="checkbox"/>	<input type="checkbox"/>
Physics competitions?	<input type="checkbox"/>	<input type="checkbox"/>	<input type="checkbox"/>	<input type="checkbox"/>	<input type="checkbox"/>
d) Maths-related outings with your family?	<input type="checkbox"/>	<input type="checkbox"/>	<input type="checkbox"/>	<input type="checkbox"/>	<input type="checkbox"/>
Physics-related outings with your family?	<input type="checkbox"/>	<input type="checkbox"/>	<input type="checkbox"/>	<input type="checkbox"/>	<input type="checkbox"/>
e) Maths-related outings with your school?	<input type="checkbox"/>	<input type="checkbox"/>	<input type="checkbox"/>	<input type="checkbox"/>	<input type="checkbox"/>
Physics-related outings with your school?	<input type="checkbox"/>	<input type="checkbox"/>	<input type="checkbox"/>	<input type="checkbox"/>	<input type="checkbox"/>

4. ABOUT STUDYING MATHEMATICS AND PHYSICS

		Strongly Agree	Agree	Slightly Agree	Slightly Disagree	Disagree	Strongly Disagree	Can't Say
a) i) I intend to continue to study maths/physics after this year.	Maths:	<input type="checkbox"/>	<input type="checkbox"/>	<input type="checkbox"/>	<input type="checkbox"/>	<input type="checkbox"/>	<input type="checkbox"/>	<input type="checkbox"/>
	Physics:	<input type="checkbox"/>	<input type="checkbox"/>	<input type="checkbox"/>	<input type="checkbox"/>	<input type="checkbox"/>	<input type="checkbox"/>	<input type="checkbox"/>
ii) I intend to study maths/physics at university.	Maths:	<input type="checkbox"/>	<input type="checkbox"/>	<input type="checkbox"/>	<input type="checkbox"/>	<input type="checkbox"/>	<input type="checkbox"/>	<input type="checkbox"/>
	Physics:	<input type="checkbox"/>	<input type="checkbox"/>	<input type="checkbox"/>	<input type="checkbox"/>	<input type="checkbox"/>	<input type="checkbox"/>	<input type="checkbox"/>
b) I think maths/physics is a useful subject.	Maths:	<input type="checkbox"/>	<input type="checkbox"/>	<input type="checkbox"/>	<input type="checkbox"/>	<input type="checkbox"/>	<input type="checkbox"/>	<input type="checkbox"/>
	Physics:	<input type="checkbox"/>	<input type="checkbox"/>	<input type="checkbox"/>	<input type="checkbox"/>	<input type="checkbox"/>	<input type="checkbox"/>	<input type="checkbox"/>

		Strongly Agree	Agree	Slightly Agree	Slightly Disagree	Disagree	Strongly Disagree	Can't Say
c) I think maths/physics is an interesting subject.	Maths:	<input type="checkbox"/>	<input type="checkbox"/>	<input type="checkbox"/>	<input type="checkbox"/>	<input type="checkbox"/>	<input type="checkbox"/>	
	Physics:	<input type="checkbox"/>	<input type="checkbox"/>	<input type="checkbox"/>	<input type="checkbox"/>	<input type="checkbox"/>	<input type="checkbox"/>	
d) I think maths/physics will help me in the job I want to do in the future.	Maths:	<input type="checkbox"/>	<input type="checkbox"/>	<input type="checkbox"/>	<input type="checkbox"/>	<input type="checkbox"/>	<input type="checkbox"/>	
	Physics:	<input type="checkbox"/>	<input type="checkbox"/>	<input type="checkbox"/>	<input type="checkbox"/>	<input type="checkbox"/>	<input type="checkbox"/>	
e) My friends chose to study maths/physics.	Maths:	<input type="checkbox"/>	<input type="checkbox"/>	<input type="checkbox"/>	<input type="checkbox"/>	<input type="checkbox"/>	<input type="checkbox"/>	<input type="checkbox"/>
	Physics:	<input type="checkbox"/>	<input type="checkbox"/>	<input type="checkbox"/>	<input type="checkbox"/>	<input type="checkbox"/>	<input type="checkbox"/>	<input type="checkbox"/>
f) I am good at maths/physics.	Maths:	<input type="checkbox"/>	<input type="checkbox"/>	<input type="checkbox"/>	<input type="checkbox"/>	<input type="checkbox"/>	<input type="checkbox"/>	
	Physics:	<input type="checkbox"/>	<input type="checkbox"/>	<input type="checkbox"/>	<input type="checkbox"/>	<input type="checkbox"/>	<input type="checkbox"/>	
g) My teacher thought that I should continue with maths/physics after my GCSEs.	Maths:	<input type="checkbox"/>	<input type="checkbox"/>	<input type="checkbox"/>	<input type="checkbox"/>	<input type="checkbox"/>	<input type="checkbox"/>	<input type="checkbox"/>
	Physics:	<input type="checkbox"/>	<input type="checkbox"/>	<input type="checkbox"/>	<input type="checkbox"/>	<input type="checkbox"/>	<input type="checkbox"/>	<input type="checkbox"/>
h) My friends thought that I should continue with maths/physics after my GCSEs.	Maths:	<input type="checkbox"/>	<input type="checkbox"/>	<input type="checkbox"/>	<input type="checkbox"/>	<input type="checkbox"/>	<input type="checkbox"/>	<input type="checkbox"/>
	Physics:	<input type="checkbox"/>	<input type="checkbox"/>	<input type="checkbox"/>	<input type="checkbox"/>	<input type="checkbox"/>	<input type="checkbox"/>	<input type="checkbox"/>
i) I was advised by careers advisors that maths/physics would be a good subject to study after my GCSEs.	Maths:	<input type="checkbox"/>	<input type="checkbox"/>	<input type="checkbox"/>	<input type="checkbox"/>	<input type="checkbox"/>	<input type="checkbox"/>	<input type="checkbox"/>
	Physics:	<input type="checkbox"/>	<input type="checkbox"/>	<input type="checkbox"/>	<input type="checkbox"/>	<input type="checkbox"/>	<input type="checkbox"/>	<input type="checkbox"/>
j) I was advised by my family that maths/physics would be a good subject to study after my GCSEs.	Maths:	<input type="checkbox"/>	<input type="checkbox"/>	<input type="checkbox"/>	<input type="checkbox"/>	<input type="checkbox"/>	<input type="checkbox"/>	<input type="checkbox"/>
	Physics:	<input type="checkbox"/>	<input type="checkbox"/>	<input type="checkbox"/>	<input type="checkbox"/>	<input type="checkbox"/>	<input type="checkbox"/>	<input type="checkbox"/>
k) I was advised by someone else that maths/physics would be a good subject to study after my GCSEs.	Maths:	<input type="checkbox"/>	<input type="checkbox"/>	<input type="checkbox"/>	<input type="checkbox"/>	<input type="checkbox"/>	<input type="checkbox"/>	<input type="checkbox"/>
	Physics:	<input type="checkbox"/>	<input type="checkbox"/>	<input type="checkbox"/>	<input type="checkbox"/>	<input type="checkbox"/>	<input type="checkbox"/>	<input type="checkbox"/>
l) I worry that I will get poor grades for maths/physics.	Maths:	<input type="checkbox"/>	<input type="checkbox"/>	<input type="checkbox"/>	<input type="checkbox"/>	<input type="checkbox"/>	<input type="checkbox"/>	
	Physics:	<input type="checkbox"/>	<input type="checkbox"/>	<input type="checkbox"/>	<input type="checkbox"/>	<input type="checkbox"/>	<input type="checkbox"/>	
m) Maths/physics is one of my best subjects.	Maths:	<input type="checkbox"/>	<input type="checkbox"/>	<input type="checkbox"/>	<input type="checkbox"/>	<input type="checkbox"/>	<input type="checkbox"/>	
	Physics:	<input type="checkbox"/>	<input type="checkbox"/>	<input type="checkbox"/>	<input type="checkbox"/>	<input type="checkbox"/>	<input type="checkbox"/>	
n) I never want to take another maths/physics course.	Maths:	<input type="checkbox"/>	<input type="checkbox"/>	<input type="checkbox"/>	<input type="checkbox"/>	<input type="checkbox"/>	<input type="checkbox"/>	
	Physics:	<input type="checkbox"/>	<input type="checkbox"/>	<input type="checkbox"/>	<input type="checkbox"/>	<input type="checkbox"/>	<input type="checkbox"/>	
o) I have always done well in maths/physics.	Maths:	<input type="checkbox"/>	<input type="checkbox"/>	<input type="checkbox"/>	<input type="checkbox"/>	<input type="checkbox"/>	<input type="checkbox"/>	
	Physics:	<input type="checkbox"/>	<input type="checkbox"/>	<input type="checkbox"/>	<input type="checkbox"/>	<input type="checkbox"/>	<input type="checkbox"/>	

5. CHANGES IN STUDYING

	Yes	No
a) Are you aware of any changes in your intention to take mathematics over the last two years?	<input type="checkbox"/>	<input type="checkbox"/>
b) Are you aware of any changes in your intention to take physics over the last two years?	<input type="checkbox"/>	<input type="checkbox"/>

		It was an incentive or reason to take the subject	It was a disincentive or reason not to take the subject
c) If yes, was it an influence from:			
i) a teacher?	Maths:	<input type="checkbox"/>	<input type="checkbox"/>
	Physics:	<input type="checkbox"/>	<input type="checkbox"/>
ii) my parents or family?	Maths:	<input type="checkbox"/>	<input type="checkbox"/>
	Physics:	<input type="checkbox"/>	<input type="checkbox"/>
iii) my friends or peers?	Maths:	<input type="checkbox"/>	<input type="checkbox"/>
	Physics:	<input type="checkbox"/>	<input type="checkbox"/>
iv) an out of school experience?	Maths:	<input type="checkbox"/>	<input type="checkbox"/>
	Physics:	<input type="checkbox"/>	<input type="checkbox"/>
v) a teaching or learning activity?	Maths:	<input type="checkbox"/>	<input type="checkbox"/>
	Physics:	<input type="checkbox"/>	<input type="checkbox"/>
vi) course content?	Maths:	<input type="checkbox"/>	<input type="checkbox"/>
	Physics:	<input type="checkbox"/>	<input type="checkbox"/>
vii) a perception of the limits of my competence?	Maths:	<input type="checkbox"/>	<input type="checkbox"/>
	Physics:	<input type="checkbox"/>	<input type="checkbox"/>
viii) an exam result?	Maths:	<input type="checkbox"/>	<input type="checkbox"/>
	Physics:	<input type="checkbox"/>	<input type="checkbox"/>
ix) the subject's usefulness to my career plans?	Maths:	<input type="checkbox"/>	<input type="checkbox"/>
	Physics:	<input type="checkbox"/>	<input type="checkbox"/>
x) a change in my expectations of what I can do with my life?	Maths:	<input type="checkbox"/>	<input type="checkbox"/>
	Physics:	<input type="checkbox"/>	<input type="checkbox"/>
xi) another reason?	Maths:	<input type="checkbox"/>	<input type="checkbox"/>
	Physics:	<input type="checkbox"/>	<input type="checkbox"/>

6. YOUR VIEWS ON MATHEMATICS AND PHYSICS

		Strongly Agree	Agree	Slightly Agree	Slightly Disagree	Disagree	Strongly Disagree	Can't Say
a)	People who are good at maths/physics get well-paid jobs.	Maths: <input type="checkbox"/>	<input type="checkbox"/>	<input type="checkbox"/>	<input type="checkbox"/>	<input type="checkbox"/>	<input type="checkbox"/>	<input type="checkbox"/>
		Physics: <input type="checkbox"/>	<input type="checkbox"/>	<input type="checkbox"/>	<input type="checkbox"/>	<input type="checkbox"/>	<input type="checkbox"/>	<input type="checkbox"/>
b)	Being good at maths/physics impresses people.	Maths: <input type="checkbox"/>	<input type="checkbox"/>	<input type="checkbox"/>	<input type="checkbox"/>	<input type="checkbox"/>	<input type="checkbox"/>	<input type="checkbox"/>
		Physics: <input type="checkbox"/>	<input type="checkbox"/>	<input type="checkbox"/>	<input type="checkbox"/>	<input type="checkbox"/>	<input type="checkbox"/>	<input type="checkbox"/>
c)	Maths/physics teaches you to think logically.	Maths: <input type="checkbox"/>	<input type="checkbox"/>	<input type="checkbox"/>	<input type="checkbox"/>	<input type="checkbox"/>	<input type="checkbox"/>	<input type="checkbox"/>
		Physics: <input type="checkbox"/>	<input type="checkbox"/>	<input type="checkbox"/>	<input type="checkbox"/>	<input type="checkbox"/>	<input type="checkbox"/>	<input type="checkbox"/>
d)	Maths/physics helps you in solving everyday problems.	Maths: <input type="checkbox"/>	<input type="checkbox"/>	<input type="checkbox"/>	<input type="checkbox"/>	<input type="checkbox"/>	<input type="checkbox"/>	<input type="checkbox"/>
		Physics: <input type="checkbox"/>	<input type="checkbox"/>	<input type="checkbox"/>	<input type="checkbox"/>	<input type="checkbox"/>	<input type="checkbox"/>	<input type="checkbox"/>
e)	Maths/physics improves your social skills.	Maths: <input type="checkbox"/>	<input type="checkbox"/>	<input type="checkbox"/>	<input type="checkbox"/>	<input type="checkbox"/>	<input type="checkbox"/>	<input type="checkbox"/>
		Physics: <input type="checkbox"/>	<input type="checkbox"/>	<input type="checkbox"/>	<input type="checkbox"/>	<input type="checkbox"/>	<input type="checkbox"/>	<input type="checkbox"/>
f)	To be good at maths/physics, you need to be creative.	Maths: <input type="checkbox"/>	<input type="checkbox"/>	<input type="checkbox"/>	<input type="checkbox"/>	<input type="checkbox"/>	<input type="checkbox"/>	<input type="checkbox"/>
		Physics: <input type="checkbox"/>	<input type="checkbox"/>	<input type="checkbox"/>	<input type="checkbox"/>	<input type="checkbox"/>	<input type="checkbox"/>	<input type="checkbox"/>
g)	To be good at maths/physics, you need to work hard.	Maths: <input type="checkbox"/>	<input type="checkbox"/>	<input type="checkbox"/>	<input type="checkbox"/>	<input type="checkbox"/>	<input type="checkbox"/>	<input type="checkbox"/>
		Physics: <input type="checkbox"/>	<input type="checkbox"/>	<input type="checkbox"/>	<input type="checkbox"/>	<input type="checkbox"/>	<input type="checkbox"/>	<input type="checkbox"/>
h)	Being good at maths/physics makes you popular.	Maths: <input type="checkbox"/>	<input type="checkbox"/>	<input type="checkbox"/>	<input type="checkbox"/>	<input type="checkbox"/>	<input type="checkbox"/>	<input type="checkbox"/>
		Physics: <input type="checkbox"/>	<input type="checkbox"/>	<input type="checkbox"/>	<input type="checkbox"/>	<input type="checkbox"/>	<input type="checkbox"/>	<input type="checkbox"/>
i)	Maths/physics is interesting.	Maths: <input type="checkbox"/>	<input type="checkbox"/>	<input type="checkbox"/>	<input type="checkbox"/>	<input type="checkbox"/>	<input type="checkbox"/>	<input type="checkbox"/>
		Physics: <input type="checkbox"/>	<input type="checkbox"/>	<input type="checkbox"/>	<input type="checkbox"/>	<input type="checkbox"/>	<input type="checkbox"/>	<input type="checkbox"/>
j)	Maths/physics is important in making new discoveries.	Maths: <input type="checkbox"/>	<input type="checkbox"/>	<input type="checkbox"/>	<input type="checkbox"/>	<input type="checkbox"/>	<input type="checkbox"/>	<input type="checkbox"/>
		Physics: <input type="checkbox"/>	<input type="checkbox"/>	<input type="checkbox"/>	<input type="checkbox"/>	<input type="checkbox"/>	<input type="checkbox"/>	<input type="checkbox"/>
k)	Those who are good at maths/physics are clever.	Maths: <input type="checkbox"/>	<input type="checkbox"/>	<input type="checkbox"/>	<input type="checkbox"/>	<input type="checkbox"/>	<input type="checkbox"/>	<input type="checkbox"/>
		Physics: <input type="checkbox"/>	<input type="checkbox"/>	<input type="checkbox"/>	<input type="checkbox"/>	<input type="checkbox"/>	<input type="checkbox"/>	<input type="checkbox"/>
l)	These days, everybody needs to know some maths or physics.	Maths: <input type="checkbox"/>	<input type="checkbox"/>	<input type="checkbox"/>	<input type="checkbox"/>	<input type="checkbox"/>	<input type="checkbox"/>	<input type="checkbox"/>
		Physics: <input type="checkbox"/>	<input type="checkbox"/>	<input type="checkbox"/>	<input type="checkbox"/>	<input type="checkbox"/>	<input type="checkbox"/>	<input type="checkbox"/>
m)	In maths, it is interesting to find out about the rules and patterns of numbers.	<input type="checkbox"/>	<input type="checkbox"/>	<input type="checkbox"/>	<input type="checkbox"/>	<input type="checkbox"/>	<input type="checkbox"/>	<input type="checkbox"/>
	In physics, it is interesting to find out about the laws that explain different phenomena.	<input type="checkbox"/>	<input type="checkbox"/>	<input type="checkbox"/>	<input type="checkbox"/>	<input type="checkbox"/>	<input type="checkbox"/>	<input type="checkbox"/>
n)	There is only one right way to solve any mathematical or physics problem.	Maths: <input type="checkbox"/>	<input type="checkbox"/>	<input type="checkbox"/>	<input type="checkbox"/>	<input type="checkbox"/>	<input type="checkbox"/>	<input type="checkbox"/>
		Physics: <input type="checkbox"/>	<input type="checkbox"/>	<input type="checkbox"/>	<input type="checkbox"/>	<input type="checkbox"/>	<input type="checkbox"/>	<input type="checkbox"/>

		Strongly Agree	Agree	Slightly Agree	Slightly Disagree	Disagree	Strongly Disagree	Can't Say
o) I have trouble understanding anything with maths/physics in.	Maths:	<input type="checkbox"/>	<input type="checkbox"/>	<input type="checkbox"/>	<input type="checkbox"/>	<input type="checkbox"/>	<input type="checkbox"/>	
	Physics:	<input type="checkbox"/>	<input type="checkbox"/>	<input type="checkbox"/>	<input type="checkbox"/>	<input type="checkbox"/>	<input type="checkbox"/>	
p) I hate maths/physics.	Maths:	<input type="checkbox"/>	<input type="checkbox"/>	<input type="checkbox"/>	<input type="checkbox"/>	<input type="checkbox"/>	<input type="checkbox"/>	
	Physics:	<input type="checkbox"/>	<input type="checkbox"/>	<input type="checkbox"/>	<input type="checkbox"/>	<input type="checkbox"/>	<input type="checkbox"/>	

7. LOOKING BACK AT YOUR YEAR 11 LESSONS

		Strongly Agree	Agree	Slightly Agree	Slightly Disagree	Disagree	Strongly Disagree
a) I looked forward to maths/physics classes.	Maths:	<input type="checkbox"/>	<input type="checkbox"/>	<input type="checkbox"/>	<input type="checkbox"/>	<input type="checkbox"/>	<input type="checkbox"/>
	Physics:	<input type="checkbox"/>	<input type="checkbox"/>	<input type="checkbox"/>	<input type="checkbox"/>	<input type="checkbox"/>	<input type="checkbox"/>
b) I applied the same mathematical idea to different situations. My teacher explained how a physics idea can be applied to a number of different situations.		<input type="checkbox"/>	<input type="checkbox"/>	<input type="checkbox"/>	<input type="checkbox"/>	<input type="checkbox"/>	<input type="checkbox"/>
		<input type="checkbox"/>	<input type="checkbox"/>	<input type="checkbox"/>	<input type="checkbox"/>	<input type="checkbox"/>	<input type="checkbox"/>
c) In my maths lessons, I had the opportunity to discuss my mathematical ideas. In my physics lessons, I had the opportunity to discuss my ideas about physics.		<input type="checkbox"/>	<input type="checkbox"/>	<input type="checkbox"/>	<input type="checkbox"/>	<input type="checkbox"/>	<input type="checkbox"/>
		<input type="checkbox"/>	<input type="checkbox"/>	<input type="checkbox"/>	<input type="checkbox"/>	<input type="checkbox"/>	<input type="checkbox"/>
d) I did well in my maths/physics tests.	Maths:	<input type="checkbox"/>	<input type="checkbox"/>	<input type="checkbox"/>	<input type="checkbox"/>	<input type="checkbox"/>	<input type="checkbox"/>
	Physics:	<input type="checkbox"/>	<input type="checkbox"/>	<input type="checkbox"/>	<input type="checkbox"/>	<input type="checkbox"/>	<input type="checkbox"/>
e) I enjoyed my maths/physics lessons.	Maths:	<input type="checkbox"/>	<input type="checkbox"/>	<input type="checkbox"/>	<input type="checkbox"/>	<input type="checkbox"/>	<input type="checkbox"/>
	Physics:	<input type="checkbox"/>	<input type="checkbox"/>	<input type="checkbox"/>	<input type="checkbox"/>	<input type="checkbox"/>	<input type="checkbox"/>
f) I saw the relevance of my maths/physics lessons.	Maths:	<input type="checkbox"/>	<input type="checkbox"/>	<input type="checkbox"/>	<input type="checkbox"/>	<input type="checkbox"/>	<input type="checkbox"/>
	Physics:	<input type="checkbox"/>	<input type="checkbox"/>	<input type="checkbox"/>	<input type="checkbox"/>	<input type="checkbox"/>	<input type="checkbox"/>
g) I found it difficult to apply most maths/physics concepts to everyday problems.	Maths:	<input type="checkbox"/>	<input type="checkbox"/>	<input type="checkbox"/>	<input type="checkbox"/>	<input type="checkbox"/>	<input type="checkbox"/>
	Physics:	<input type="checkbox"/>	<input type="checkbox"/>	<input type="checkbox"/>	<input type="checkbox"/>	<input type="checkbox"/>	<input type="checkbox"/>
h) When I was doing maths/physics, I always knew what I was doing.	Maths:	<input type="checkbox"/>	<input type="checkbox"/>	<input type="checkbox"/>	<input type="checkbox"/>	<input type="checkbox"/>	<input type="checkbox"/>
	Physics:	<input type="checkbox"/>	<input type="checkbox"/>	<input type="checkbox"/>	<input type="checkbox"/>	<input type="checkbox"/>	<input type="checkbox"/>

		Strongly Agree	Agree	Slightly Agree	Slightly Disagree	Disagree	Strongly Disagree
i) When I was doing maths/physics, I was learning new skills.	Maths:	<input type="checkbox"/>	<input type="checkbox"/>	<input type="checkbox"/>	<input type="checkbox"/>	<input type="checkbox"/>	<input type="checkbox"/>
	Physics:	<input type="checkbox"/>	<input type="checkbox"/>	<input type="checkbox"/>	<input type="checkbox"/>	<input type="checkbox"/>	<input type="checkbox"/>
j) When I was doing maths/physics, I was bored.	Maths:	<input type="checkbox"/>	<input type="checkbox"/>	<input type="checkbox"/>	<input type="checkbox"/>	<input type="checkbox"/>	<input type="checkbox"/>
	Physics:	<input type="checkbox"/>	<input type="checkbox"/>	<input type="checkbox"/>	<input type="checkbox"/>	<input type="checkbox"/>	<input type="checkbox"/>
k) When I was doing maths/physics, I paid attention.	Maths:	<input type="checkbox"/>	<input type="checkbox"/>	<input type="checkbox"/>	<input type="checkbox"/>	<input type="checkbox"/>	<input type="checkbox"/>
	Physics:	<input type="checkbox"/>	<input type="checkbox"/>	<input type="checkbox"/>	<input type="checkbox"/>	<input type="checkbox"/>	<input type="checkbox"/>
l) When I was doing maths/physics, I got upset.	Maths:	<input type="checkbox"/>	<input type="checkbox"/>	<input type="checkbox"/>	<input type="checkbox"/>	<input type="checkbox"/>	<input type="checkbox"/>
	Physics:	<input type="checkbox"/>	<input type="checkbox"/>	<input type="checkbox"/>	<input type="checkbox"/>	<input type="checkbox"/>	<input type="checkbox"/>
m) When I was doing maths/physics, I daydreamed.	Maths:	<input type="checkbox"/>	<input type="checkbox"/>	<input type="checkbox"/>	<input type="checkbox"/>	<input type="checkbox"/>	<input type="checkbox"/>
	Physics:	<input type="checkbox"/>	<input type="checkbox"/>	<input type="checkbox"/>	<input type="checkbox"/>	<input type="checkbox"/>	<input type="checkbox"/>
n) I liked my maths/physics teacher.	Maths:	<input type="checkbox"/>	<input type="checkbox"/>	<input type="checkbox"/>	<input type="checkbox"/>	<input type="checkbox"/>	<input type="checkbox"/>
	Physics:	<input type="checkbox"/>	<input type="checkbox"/>	<input type="checkbox"/>	<input type="checkbox"/>	<input type="checkbox"/>	<input type="checkbox"/>

		Near top	A bit above average	Average	A bit below average	Near bottom
x) Thinking about your maths/physics lessons, how did you feel you compared with the others in your group?	Maths:	<input type="checkbox"/>	<input type="checkbox"/>	<input type="checkbox"/>	<input type="checkbox"/>	<input type="checkbox"/>
	Physics:	<input type="checkbox"/>	<input type="checkbox"/>	<input type="checkbox"/>	<input type="checkbox"/>	<input type="checkbox"/>

8. LOOKING BACK AT YOUR YEAR 11 MATHEMATICS AND PHYSICS TEACHERS

		Strongly Agree	Agree	Slightly Agree	Slightly Disagree	Disagree	Strongly Disagree	Can't Say
a) My maths/physics teacher had high expectations of what the students could learn.	Maths:	<input type="checkbox"/>	<input type="checkbox"/>	<input type="checkbox"/>	<input type="checkbox"/>	<input type="checkbox"/>	<input type="checkbox"/>	<input type="checkbox"/>
	Physics:	<input type="checkbox"/>	<input type="checkbox"/>	<input type="checkbox"/>	<input type="checkbox"/>	<input type="checkbox"/>	<input type="checkbox"/>	<input type="checkbox"/>
b) My maths/physics teacher believed that all students could learn maths or physics.	Maths:	<input type="checkbox"/>	<input type="checkbox"/>	<input type="checkbox"/>	<input type="checkbox"/>	<input type="checkbox"/>	<input type="checkbox"/>	<input type="checkbox"/>
	Physics:	<input type="checkbox"/>	<input type="checkbox"/>	<input type="checkbox"/>	<input type="checkbox"/>	<input type="checkbox"/>	<input type="checkbox"/>	<input type="checkbox"/>

		Strongly Agree	Agree	Slightly Agree	Slightly Disagree	Disagree	Strongly Disagree	Can't Say
c)	My maths/physics teacher wanted us to really understand maths or physics.	Maths: <input type="checkbox"/>	<input type="checkbox"/>	<input type="checkbox"/>	<input type="checkbox"/>	<input type="checkbox"/>	<input type="checkbox"/>	<input type="checkbox"/>
		Physics: <input type="checkbox"/>	<input type="checkbox"/>	<input type="checkbox"/>	<input type="checkbox"/>	<input type="checkbox"/>	<input type="checkbox"/>	<input type="checkbox"/>
d)	My maths/physics teacher set us homework.	Maths: <input type="checkbox"/>	<input type="checkbox"/>	<input type="checkbox"/>	<input type="checkbox"/>	<input type="checkbox"/>	<input type="checkbox"/>	<input type="checkbox"/>
		Physics: <input type="checkbox"/>	<input type="checkbox"/>	<input type="checkbox"/>	<input type="checkbox"/>	<input type="checkbox"/>	<input type="checkbox"/>	<input type="checkbox"/>
e)	My maths/physics teacher believed that mistakes were OK as long as we were learning.	Maths: <input type="checkbox"/>	<input type="checkbox"/>	<input type="checkbox"/>	<input type="checkbox"/>	<input type="checkbox"/>	<input type="checkbox"/>	<input type="checkbox"/>
		Physics: <input type="checkbox"/>	<input type="checkbox"/>	<input type="checkbox"/>	<input type="checkbox"/>	<input type="checkbox"/>	<input type="checkbox"/>	<input type="checkbox"/>
f)	My maths/physics teacher was interested in me as a person.	Maths: <input type="checkbox"/>	<input type="checkbox"/>	<input type="checkbox"/>	<input type="checkbox"/>	<input type="checkbox"/>	<input type="checkbox"/>	<input type="checkbox"/>
		Physics: <input type="checkbox"/>	<input type="checkbox"/>	<input type="checkbox"/>	<input type="checkbox"/>	<input type="checkbox"/>	<input type="checkbox"/>	<input type="checkbox"/>
g)	My maths/physics teacher seemed to like all the students.	Maths: <input type="checkbox"/>	<input type="checkbox"/>	<input type="checkbox"/>	<input type="checkbox"/>	<input type="checkbox"/>	<input type="checkbox"/>	<input type="checkbox"/>
		Physics: <input type="checkbox"/>	<input type="checkbox"/>	<input type="checkbox"/>	<input type="checkbox"/>	<input type="checkbox"/>	<input type="checkbox"/>	<input type="checkbox"/>
h)	My maths/physics teacher was interested in what the students thought.	Maths: <input type="checkbox"/>	<input type="checkbox"/>	<input type="checkbox"/>	<input type="checkbox"/>	<input type="checkbox"/>	<input type="checkbox"/>	<input type="checkbox"/>
		Physics: <input type="checkbox"/>	<input type="checkbox"/>	<input type="checkbox"/>	<input type="checkbox"/>	<input type="checkbox"/>	<input type="checkbox"/>	<input type="checkbox"/>
i)	My maths/physics teacher only cared about students who got good marks in their subject.	Maths: <input type="checkbox"/>	<input type="checkbox"/>	<input type="checkbox"/>	<input type="checkbox"/>	<input type="checkbox"/>	<input type="checkbox"/>	<input type="checkbox"/>
		Physics: <input type="checkbox"/>	<input type="checkbox"/>	<input type="checkbox"/>	<input type="checkbox"/>	<input type="checkbox"/>	<input type="checkbox"/>	<input type="checkbox"/>
j)	My maths/physics teacher let us get away with not doing our homework.	Maths: <input type="checkbox"/>	<input type="checkbox"/>	<input type="checkbox"/>	<input type="checkbox"/>	<input type="checkbox"/>	<input type="checkbox"/>	<input type="checkbox"/>
		Physics: <input type="checkbox"/>	<input type="checkbox"/>	<input type="checkbox"/>	<input type="checkbox"/>	<input type="checkbox"/>	<input type="checkbox"/>	<input type="checkbox"/>
k)	My maths/physics teacher treated all students the same regardless of their ability in the subject.	Maths: <input type="checkbox"/>	<input type="checkbox"/>	<input type="checkbox"/>	<input type="checkbox"/>	<input type="checkbox"/>	<input type="checkbox"/>	<input type="checkbox"/>
		Physics: <input type="checkbox"/>	<input type="checkbox"/>	<input type="checkbox"/>	<input type="checkbox"/>	<input type="checkbox"/>	<input type="checkbox"/>	<input type="checkbox"/>
l)	My maths/physics teacher was good at explaining maths or physics.	Maths: <input type="checkbox"/>	<input type="checkbox"/>	<input type="checkbox"/>	<input type="checkbox"/>	<input type="checkbox"/>	<input type="checkbox"/>	<input type="checkbox"/>
		Physics: <input type="checkbox"/>	<input type="checkbox"/>	<input type="checkbox"/>	<input type="checkbox"/>	<input type="checkbox"/>	<input type="checkbox"/>	<input type="checkbox"/>
m)	My maths/physics teacher marked and returned homework quickly.	Maths: <input type="checkbox"/>	<input type="checkbox"/>	<input type="checkbox"/>	<input type="checkbox"/>	<input type="checkbox"/>	<input type="checkbox"/>	<input type="checkbox"/>
		Physics: <input type="checkbox"/>	<input type="checkbox"/>	<input type="checkbox"/>	<input type="checkbox"/>	<input type="checkbox"/>	<input type="checkbox"/>	<input type="checkbox"/>

9. HELP WITH MATHEMATICS AND PHYSICS DURING YEAR 11

		Strongly Agree	Agree	Slightly Agree	Slightly Disagree	Disagree	Strongly Disagree	Can't Say
a)	I needed help with maths/physics.	Maths: <input type="checkbox"/>	<input type="checkbox"/>	<input type="checkbox"/>	<input type="checkbox"/>	<input type="checkbox"/>	<input type="checkbox"/>	<input type="checkbox"/>
		Physics: <input type="checkbox"/>	<input type="checkbox"/>	<input type="checkbox"/>	<input type="checkbox"/>	<input type="checkbox"/>	<input type="checkbox"/>	<input type="checkbox"/>
b)	I did extra maths/physics work at home (i.e. work not set by teachers).	Maths: <input type="checkbox"/>	<input type="checkbox"/>	<input type="checkbox"/>	<input type="checkbox"/>	<input type="checkbox"/>	<input type="checkbox"/>	<input type="checkbox"/>
		Physics: <input type="checkbox"/>	<input type="checkbox"/>	<input type="checkbox"/>	<input type="checkbox"/>	<input type="checkbox"/>	<input type="checkbox"/>	<input type="checkbox"/>
c)	Did any of these people ever help you with your maths/physics work:							
	i) Someone in my family.	Maths: <input type="checkbox"/>	<input type="checkbox"/>	<input type="checkbox"/>	<input type="checkbox"/>	<input type="checkbox"/>	<input type="checkbox"/>	<input type="checkbox"/>
		Physics: <input type="checkbox"/>	<input type="checkbox"/>	<input type="checkbox"/>	<input type="checkbox"/>	<input type="checkbox"/>	<input type="checkbox"/>	<input type="checkbox"/>
	ii) My friend(s).	Maths: <input type="checkbox"/>	<input type="checkbox"/>	<input type="checkbox"/>	<input type="checkbox"/>	<input type="checkbox"/>	<input type="checkbox"/>	<input type="checkbox"/>
		Physics: <input type="checkbox"/>	<input type="checkbox"/>	<input type="checkbox"/>	<input type="checkbox"/>	<input type="checkbox"/>	<input type="checkbox"/>	<input type="checkbox"/>
	iii) A private tutor.	Maths: <input type="checkbox"/>	<input type="checkbox"/>	<input type="checkbox"/>	<input type="checkbox"/>	<input type="checkbox"/>	<input type="checkbox"/>	<input type="checkbox"/>
		Physics: <input type="checkbox"/>	<input type="checkbox"/>	<input type="checkbox"/>	<input type="checkbox"/>	<input type="checkbox"/>	<input type="checkbox"/>	<input type="checkbox"/>
	iv) My teacher.	Maths: <input type="checkbox"/>	<input type="checkbox"/>	<input type="checkbox"/>	<input type="checkbox"/>	<input type="checkbox"/>	<input type="checkbox"/>	<input type="checkbox"/>
		Physics: <input type="checkbox"/>	<input type="checkbox"/>	<input type="checkbox"/>	<input type="checkbox"/>	<input type="checkbox"/>	<input type="checkbox"/>	<input type="checkbox"/>
	v) Someone else not listed above.	Maths: <input type="checkbox"/>	<input type="checkbox"/>	<input type="checkbox"/>	<input type="checkbox"/>	<input type="checkbox"/>	<input type="checkbox"/>	<input type="checkbox"/>
		Physics: <input type="checkbox"/>	<input type="checkbox"/>	<input type="checkbox"/>	<input type="checkbox"/>	<input type="checkbox"/>	<input type="checkbox"/>	<input type="checkbox"/>

10. YOUR LEARNING

		Strongly Agree	Agree	Slightly Agree	Slightly Disagree	Disagree	Strongly Disagree
a)	I like school tasks the best that really make me think.	<input type="checkbox"/>	<input type="checkbox"/>	<input type="checkbox"/>	<input type="checkbox"/>	<input type="checkbox"/>	<input type="checkbox"/>
b)	I like work that I learn from, even if I make a lot of mistakes.	<input type="checkbox"/>	<input type="checkbox"/>	<input type="checkbox"/>	<input type="checkbox"/>	<input type="checkbox"/>	<input type="checkbox"/>
c)	It is important for me to improve my skills.	<input type="checkbox"/>	<input type="checkbox"/>	<input type="checkbox"/>	<input type="checkbox"/>	<input type="checkbox"/>	<input type="checkbox"/>
d)	It is important for me to learn something new.	<input type="checkbox"/>	<input type="checkbox"/>	<input type="checkbox"/>	<input type="checkbox"/>	<input type="checkbox"/>	<input type="checkbox"/>
e)	I know how well I am doing in this school.	<input type="checkbox"/>	<input type="checkbox"/>	<input type="checkbox"/>	<input type="checkbox"/>	<input type="checkbox"/>	<input type="checkbox"/>

How many meetings or interviews within school did you have to obtain formal advice regarding what you do after your GCSEs or equivalent qualification, in:

g) Years 8 to 9?	
h) Year 10?	
i) Year 11?	

11. YOUR FAMILY'S VIEWS

		Strongly Agree	Agree	Slightly Agree	Slightly Disagree	Disagree	Strongly Disagree	Can't Say
a) During Year 11, someone in my family:								
i) wanted me to work hard and try to the best of my ability.		<input type="checkbox"/>	<input type="checkbox"/>	<input type="checkbox"/>	<input type="checkbox"/>	<input type="checkbox"/>	<input type="checkbox"/>	<input type="checkbox"/>
ii) wanted me to be successful in the subjects that I am interested in.		<input type="checkbox"/>	<input type="checkbox"/>	<input type="checkbox"/>	<input type="checkbox"/>	<input type="checkbox"/>	<input type="checkbox"/>	<input type="checkbox"/>
iii) wanted me to do well in order to a good job.		<input type="checkbox"/>	<input type="checkbox"/>	<input type="checkbox"/>	<input type="checkbox"/>	<input type="checkbox"/>	<input type="checkbox"/>	<input type="checkbox"/>
iv) wanted me to be successful at school in maths/physics.	Maths:	<input type="checkbox"/>	<input type="checkbox"/>	<input type="checkbox"/>	<input type="checkbox"/>	<input type="checkbox"/>	<input type="checkbox"/>	<input type="checkbox"/>
	Physics:	<input type="checkbox"/>	<input type="checkbox"/>	<input type="checkbox"/>	<input type="checkbox"/>	<input type="checkbox"/>	<input type="checkbox"/>	<input type="checkbox"/>
v) wanted me to be the best in my class in maths/physics.	Maths:	<input type="checkbox"/>	<input type="checkbox"/>	<input type="checkbox"/>	<input type="checkbox"/>	<input type="checkbox"/>	<input type="checkbox"/>	<input type="checkbox"/>
	Physics:	<input type="checkbox"/>	<input type="checkbox"/>	<input type="checkbox"/>	<input type="checkbox"/>	<input type="checkbox"/>	<input type="checkbox"/>	<input type="checkbox"/>
vi) wanted me to talk to them about my maths or physics work.	Maths:	<input type="checkbox"/>	<input type="checkbox"/>	<input type="checkbox"/>	<input type="checkbox"/>	<input type="checkbox"/>	<input type="checkbox"/>	<input type="checkbox"/>
	Physics:	<input type="checkbox"/>	<input type="checkbox"/>	<input type="checkbox"/>	<input type="checkbox"/>	<input type="checkbox"/>	<input type="checkbox"/>	<input type="checkbox"/>
vii) thought that you have to be born with maths or physics talent to do well at it.	Maths:	<input type="checkbox"/>	<input type="checkbox"/>	<input type="checkbox"/>	<input type="checkbox"/>	<input type="checkbox"/>	<input type="checkbox"/>	<input type="checkbox"/>
	Physics:	<input type="checkbox"/>	<input type="checkbox"/>	<input type="checkbox"/>	<input type="checkbox"/>	<input type="checkbox"/>	<input type="checkbox"/>	<input type="checkbox"/>
viii) thought that I should continue with maths or physics after my GCSEs.	Maths:	<input type="checkbox"/>	<input type="checkbox"/>	<input type="checkbox"/>	<input type="checkbox"/>	<input type="checkbox"/>	<input type="checkbox"/>	<input type="checkbox"/>
	Physics:	<input type="checkbox"/>	<input type="checkbox"/>	<input type="checkbox"/>	<input type="checkbox"/>	<input type="checkbox"/>	<input type="checkbox"/>	<input type="checkbox"/>
ix) thought that anyone can do maths or physics if they try hard enough.	Maths:	<input type="checkbox"/>	<input type="checkbox"/>	<input type="checkbox"/>	<input type="checkbox"/>	<input type="checkbox"/>	<input type="checkbox"/>	<input type="checkbox"/>
	Physics:	<input type="checkbox"/>	<input type="checkbox"/>	<input type="checkbox"/>	<input type="checkbox"/>	<input type="checkbox"/>	<input type="checkbox"/>	<input type="checkbox"/>

12. MATHEMATICS TASKS

These tasks have nothing to do with your school marks and your answers will not be seen by your teachers or anyone else at your school. We simply would like to compare your answers to these task items with your attitudes to maths.

T1. TILES

Raj has some white square tiles and some grey square tiles.

They are all the same size.

She makes a row of six white tiles.

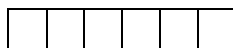

She surrounds the white tiles with a single layer of grey tiles.

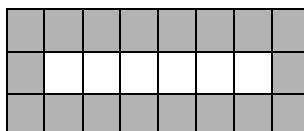

Then she makes a row of twelve white tiles.

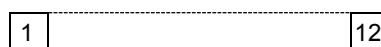

And then she surrounds these white tiles with grey tiles.



a) How many grey tiles does she use to surround a row of 12 white tiles?

Show your working here:

b) How many grey tiles does she need to surround a row of 60 white tiles?

Show your working here:

c) How confident are you that your answer to **part (b)** is correct?

Very confident Fairly confident Not confident Just guessing

d) Write a rule for the number of grey tiles needed to surround a row of n white tiles.
You can write a sentence or use algebra.

e) How confident are you that your answer to **part (d)** is correct?

Very confident Fairly confident Not confident Just guessing

T2. How much do you agree with the following statements?

I find doing 'find the pattern' problems:

a) Enjoyable

b) Easy

c) Interesting

	Strongly Agree	Agree	Slightly Agree	Slightly Disagree	Disagree	Strongly Disagree
a) Enjoyable	<input type="checkbox"/>	<input type="checkbox"/>	<input type="checkbox"/>	<input type="checkbox"/>	<input type="checkbox"/>	<input type="checkbox"/>
b) Easy	<input type="checkbox"/>	<input type="checkbox"/>	<input type="checkbox"/>	<input type="checkbox"/>	<input type="checkbox"/>	<input type="checkbox"/>
c) Interesting	<input type="checkbox"/>	<input type="checkbox"/>	<input type="checkbox"/>	<input type="checkbox"/>	<input type="checkbox"/>	<input type="checkbox"/>

13. PHYSICS TASKS

These tasks have nothing to do with your school marks and your answers will not be seen by your teachers or anyone else at your school. We simply would like to compare your answers to these task items with your attitudes to physics.

E1. ELECTRICITY 1

In this circuit below, the reading on ammeter A_1 is 0.4 amps.

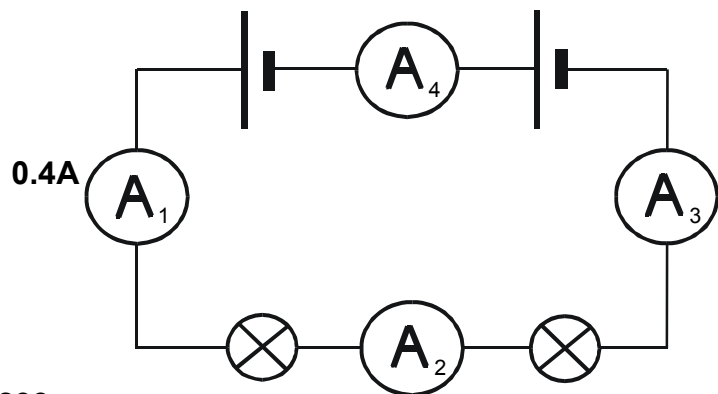

What reading you would expect to see

(a) .. on ammeter A_2 ?

(b) .. on ammeter A_3 ?

(c) .. on ammeter A_4 ?

Put a cross in ONE box

Put a cross in ONE box

Put a cross in ONE box

More than 0.4A

More than 0.4A

More than 0.4A

Exactly 0.4A

Exactly 0.4A

Exactly 0.4A

Less than 0.4A, but not zero

Less than 0.4A, but not zero

Less than 0.4A, but not zero

Zero

Zero

Zero

(d) Put a cross in ONE box below to explain your reason for choosing these answers.

- The current is the same all round the circuit.
- Each bulb uses up **some** of the current, leaving less for the next one.
- The first bulb uses up **all** of the current.
- The current is large close to the battery, and smaller further away.
- The reading is biggest where the currents from the two ends of the battery meet.

(e) How confident are you that your answers to question E1 are correct?

- Very confident Fairly confident Not confident Just guessing

E2. How much do you agree with the following statements?

	Strongly Agree	Agree	Slightly Agree	Slightly Disagree	Disagree	Strongly Disagree
I find doing 'electricity' problems:						
a) Enjoyable	<input type="checkbox"/>	<input type="checkbox"/>	<input type="checkbox"/>	<input type="checkbox"/>	<input type="checkbox"/>	<input type="checkbox"/>
b) Easy	<input type="checkbox"/>	<input type="checkbox"/>	<input type="checkbox"/>	<input type="checkbox"/>	<input type="checkbox"/>	<input type="checkbox"/>
c) Interesting	<input type="checkbox"/>	<input type="checkbox"/>	<input type="checkbox"/>	<input type="checkbox"/>	<input type="checkbox"/>	<input type="checkbox"/>

F1. FORCES 1

Kim throws a tennis ball straight up into the air. It goes up and comes back down into her hand.

Think about the moment when the ball is at A, **on the way up** to its highest point.

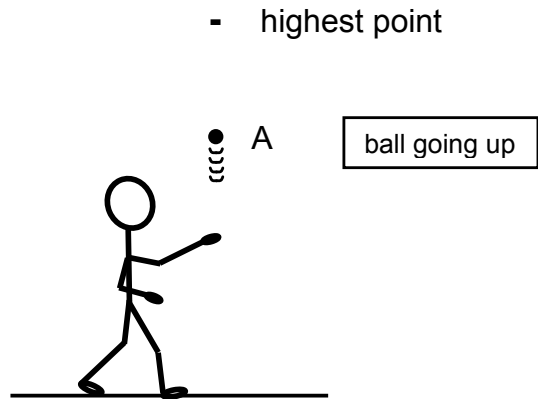

(a) How would you describe the motion of the ball at this instant?

Put a cross in ONE box only

- It is getting faster.
- It is moving at a steady speed.
- It is slowing down.

(b) Which of the following diagrams best shows the **vertical** forces on the ball when it is **at point A on the way up**?

(The length of the arrow indicates the size of each force.)

Put a cross in ONE box only

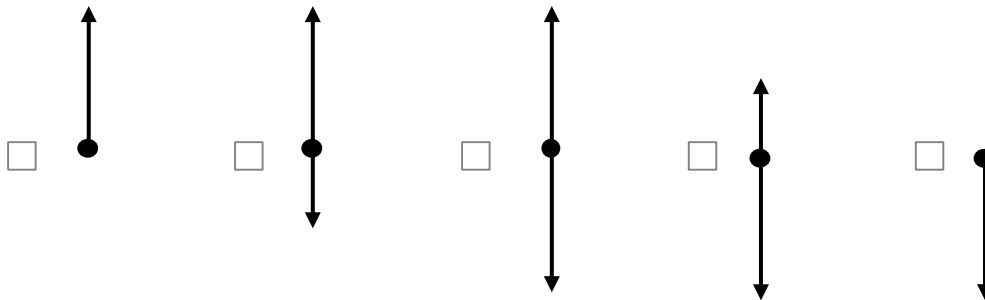

(c) Which of the following best describes the forces acting on the ball when it is **at point A on the way up?**

Put a cross in ONE box only

- The only force acting on the ball is the upward force of the throw.
- The only force acting on the ball is the downward force of gravity.
- The forces acting on the ball are the force of gravity, and the air resistance.
- The forces acting on the ball are the force of gravity, the air resistance, and the force of the throw.
- There are no forces acting on the ball.

(d) Which of the following diagrams best shows the **total force** acting on the ball when it is **at point A on the way up?**

- highest point

Put a cross in ONE box only

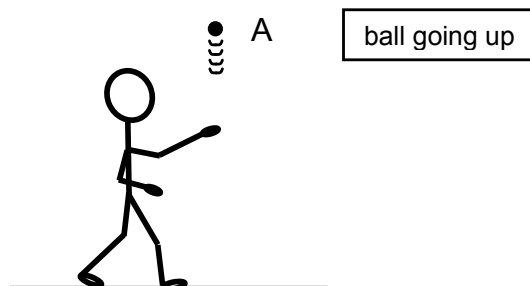
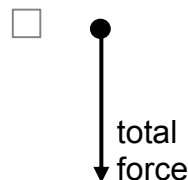
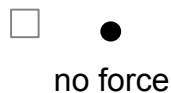
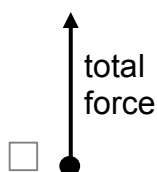

(e) How confident are you that your answers to this question (F1) are correct?

- Very confident Fairly confident Not confident Just guessing

F2. How much do you agree with the following statements?

	Strongly Agree	Agree	Slightly Agree	Slightly Disagree	Disagree	Strongly Disagree
I find doing 'forces' problems:						
a) Enjoyable	<input type="checkbox"/>	<input type="checkbox"/>	<input type="checkbox"/>	<input type="checkbox"/>	<input type="checkbox"/>	<input type="checkbox"/>
b) Easy	<input type="checkbox"/>	<input type="checkbox"/>	<input type="checkbox"/>	<input type="checkbox"/>	<input type="checkbox"/>	<input type="checkbox"/>
c) Interesting	<input type="checkbox"/>	<input type="checkbox"/>	<input type="checkbox"/>	<input type="checkbox"/>	<input type="checkbox"/>	<input type="checkbox"/>

Thank You